



**HORSTMANN**

# **HRT4-B User and Installation Instructions**

**Battery Operated Electronic Room Thermostat  
with TPI temperature control software**



The HRT4-B is a battery powered electronic room thermostat designed to provide optimum comfort with close control of the energy used to heat the home.

The HRT4-B will only operate when 2 x AAA batteries have been fitted and the thermostat is wired into your central heating system.

INSTALLATION AND CONNECTION OF THE HRT4-B MUST BE CARRIED OUT BY A SUITABLY QUALIFIED PERSON.

WARNING: ISOLATE MAINS SUPPLY BEFORE COMMENCING INSTALLATION.

## For the user

### What is a room thermostat? ... **an explanation for householders**

A room thermostat simply switches the heating system on and off as necessary. It works by sensing the air temperature, switching on the heating when the air temperature falls below the thermostat setting, and switching it off once this set temperature has been reached.

Turning a room thermostat to a higher setting will not make the room heat up any faster. How quickly the room heats up depends on the design of the heating system, for example, the size of boiler and radiators.

Neither does the setting affect how quickly the room cools down. Turning a room thermostat to a lower setting will result in the room being controlled at a lower temperature, and saves energy.

The heating system will not work if a time switch or programmer has switched it off.

The way to set and use your room thermostat is to find the lowest temperature setting that you are comfortable with, and then leave it alone to do its job. The best way to do this is to set the room thermostat to a low temperature - say 18°C - and then turn it up by one degree each day until you are comfortable with the temperature. You won't have to adjust the thermostat further. Any adjustment above this setting will waste energy and cost you more money.

If your heating system is a boiler with radiators, there will usually be only one room thermostat to control the whole house. But you can have different temperatures in individual rooms by installing thermostatic radiator valves (TRVs) on individual radiators. If you don't have TRVs, you should choose a temperature that is reasonable for the whole house. If you do have TRVs, you can choose a slightly higher setting to make sure that even the coldest room is comfortable, then prevent any overheating in other rooms by adjusting the TRVs.

Room thermostats need a free flow of air to sense the temperature, so they must not be covered by curtains or blocked by furniture. Nearby electric fires, televisions, wall or table lamps may prevent the thermostat from working properly.

### **Additional User information**

The Horstmann HRT4-B thermostat uses the latest control technology to provide extremely accurate temperature control which will help to keep your energy usage as low as possible without affecting your comfort levels. In fact comfort levels may well be improved as the control accuracy should ensure that the room does not 'overheat' before switching off.

# User Instructions

The display will show the required temperature setting and can be adjusted in increments of 1°C.

To adjust the required temperature setting turn the dial anti clockwise to decrease it and clockwise to increase it.



Pressing the temperature setting dial will allow the user to check the current room temperature which will be displayed for approx 7 seconds before returning to the set temperature.



When the thermostat is in the 'call for heat' condition a flame symbol will appear in the display.



Further information on how the thermostat operates is contained in the 'Explanation for householders' that precedes this section.

## Battery replacement

The HRT4-B runs on 2 x type AAA (Alkaline) non rechargeable batteries and is designed to give a battery life of approximately two years.

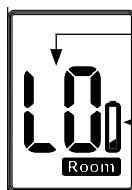

Batteries should be changed immediately

Low battery symbol appears first when the batteries are nearing the end of their life

When the batteries are nearing the end of their life a low battery symbol will appear in the display and the batteries should be changed within a few days. If the batteries are not changed at this point eventually a 'LO' battery message flashes intermittently in the display and if this happens the batteries should be changed immediately.

To change the batteries it is necessary to remove the thermostat from the wall.

To do this first undo the two captive screws at the base of the thermostat and swing the thermostat up and away from the wall plate.

**N.B. The wall plate must not be altered or modified as it has been specially designed to isolate the mains supply when the thermostat is removed to change the batteries.**

Remove the old batteries and replace them with two new AAA size alkaline batteries ensuring that they are fitted correctly as indicated by the terminal markings in the battery compartments.

**Please dispose of the batteries responsibly.**

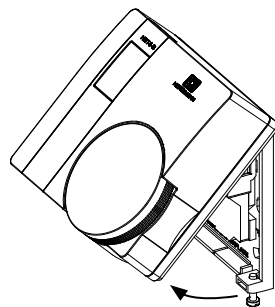

Once the batteries are fitted, re-fit the thermostat to the wall plate by engaging with the lugs at the top of the wall plate and push the thermostat into position. Locate it over the captive screws at the base of the wall plate and tighten so that the thermostat is locked into position.

Check the temperature setting is correct and adjust if necessary.

# Installation Instructions

**Warning isolate mains supply before commencing installation.**

## Positioning the Room Thermostat

The HRT4-B should be mounted on an internal wall approximately 1.5 metres from floor level and should be in a position away from draughts, direct heat and sunlight. Ensure that there will be enough space to allow easy access to the two retaining screws located at the base of the wall plate.

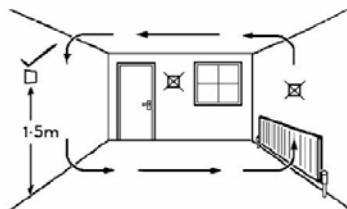

## Fitting the wall plate

To remove the wall plate from the HRT4-B undo the two retaining screws located on the underside, the wall plate should now be easily removed. Once the wall plate has been removed from the packaging please ensure the HRT4-B is re-sealed to prevent damage from dust, debris etc.

The wall plate should be fitted with the wiring terminals located at the top and in a position which allows a total clearance of at least 50mm around the HRT4-B thermostat.

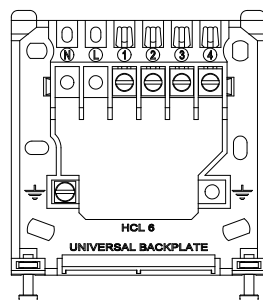

## Direct Wall Mounting

Offer the plate to the wall in the position the HRT4-B is to be mounted and mark the fixing positions through the slots in the wall plate. Drill and plug the wall, then secure the plate in position. The slots in the wall plate will compensate for any misalignment of the fixings.

## Wiring Box Mounting

The HRT4-B wall plate may be fitted directly on to a single gang steel flush wiring box complying with BS4662, using two M3.5 screws. The HRT4-B is suitable for mounting on a flat surface only; it must not be positioned on an unearthed metal surface.

## Electrical Connections

All necessary electrical connections should now be made. Flush wiring can enter from the rear through the aperture in the wall plate. For mains voltage applications a 3 Amp fused spur should be used. The recommended cable size is 1.0mm<sup>2</sup>.

**The wall plate is provided with a terminal guard to protect the user when replacing the batteries. This is supplied with the wall plate and it is essential that the terminal guard is fitted after completing the electrical connections to the terminals of the wall plate.**

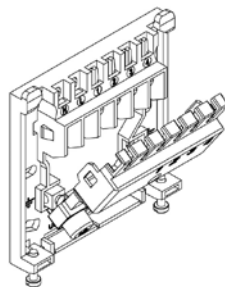

**FAILURE TO DO THIS COULD RESULT IN ELECTRIC SHOCK WHEN CHANGING BATTERIES.**

As access to the terminals will not be possible once the terminal guard is fitted only fit the guard when all wiring is complete and the system checked for correct operation.

# HRT4-B thermostat – internal wiring diagram

The HRT4-B is double insulated and does not require an earth connection, an earth connection block is provided on the wall plate for terminating any cable earth conductors. Earth continuity must be maintained and all bare earth conductors must be sleeved. Ensure that no conductors are left protruding outside the central space enclosed by the wall plate.

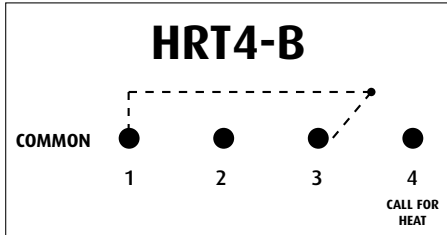

- The HRT4-B has voltage free contacts.
- The HRT4-B is battery powered, therefore no mains connection is required to power it.

**Please ensure that all wiring complies with the current IEE regulations.**

## Typical combination boiler installation for boiler with built in timer and external room 'stat

HRT4-B terminal connections

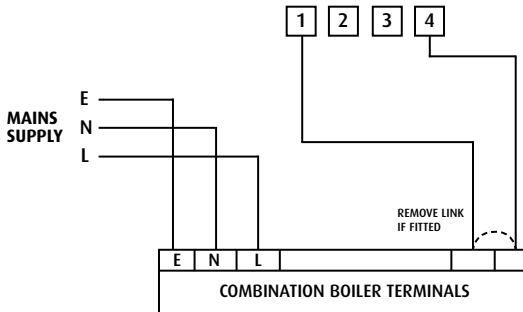

## Typical combination boiler installation with ChannelPlus H11XL time switch and HRT4-B room thermostat

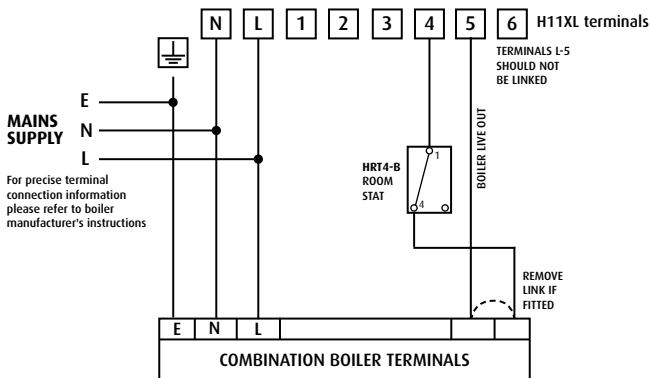

**These diagrams are schematic and should be used for guidance only.**

**Fully Pumped Heating System using HRT4-B room stat, cylinder stat and Three Port Mid Position Valve with a Horstmann ChannelPlus H21/H27 electronic programmer.**

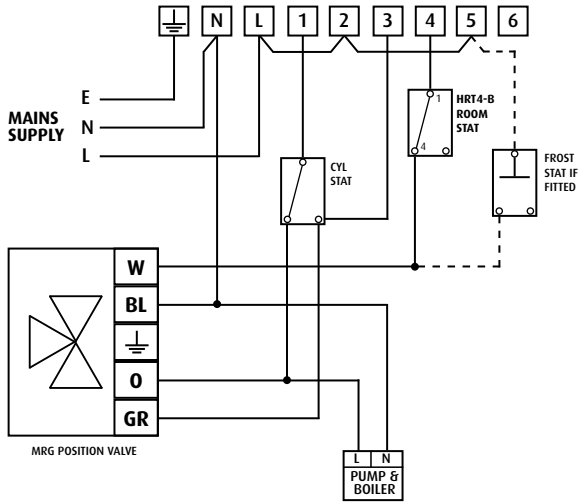

**Fully Pumped Heating System using HRT4-B room stat, cylinder stat and Two (2 Port) Spring Return Valves with auxiliary switches and a Horstmann ChannelPlus H21/H27 electronic programmer.**

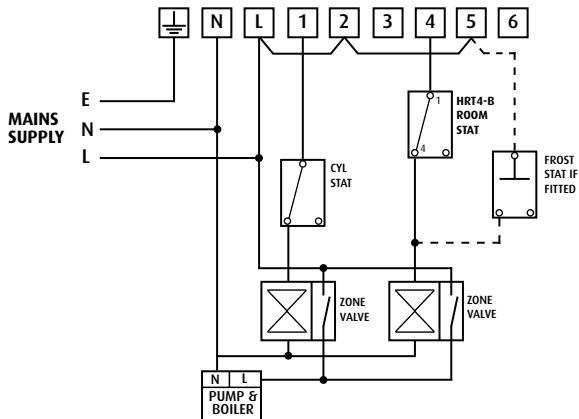

INSTALLATION AND CONNECTION OF THE HRT4-B MUST BE CARRIED OUT BY A SUITABLY QUALIFIED PERSON. **WARNING: ISOLATE MAINS SUPPLY BEFORE COMMENCING INSTALLATION.**

**These diagrams are schematic and should be used for guidance only.**

## Fitting the thermostat to the wall plate

**Ensure the terminal guard is fitted into place over the terminals of the wall plate.** Fit the two AAA batteries provided, ensuring they are installed correctly as indicated by the terminal markings in the battery compartment. Ensure that the electricity supply to the HRT4-B is switched **OFF**.

Swing the thermostat into position on the wall plate without fitting the battery terminal guard. Tighten the 2 captive screws on the underside of the unit.

Now switch **ON** the electrical circuit to the HRT4-B and observe that it switches the heating system On and Off as the temperature is turned up and down on the thermostat. If the thermostat is switching the heating system satisfactorily then switch the electricity supply to the thermostat **OFF**, remove the thermostat from the wall plate and fit the terminal guard over the terminals on the wall plate.

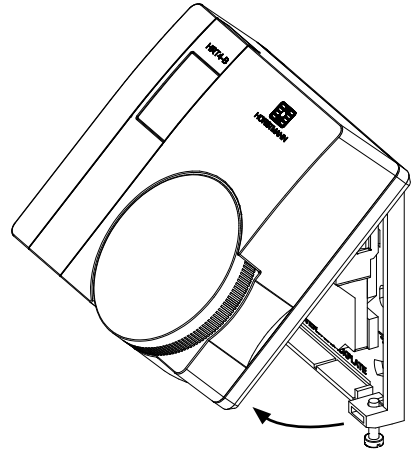

**Once clipped into position the terminal guard cannot be removed from the wall plate.**

Re-fit the thermostat into position on the wall plate and tighten the 2 captive screws on the underside of the unit. Switch on the electricity supply to the HRT4-B and check again for correct operation.

Explain its operation to the householder before handing over these instructions, highlighting the 'explanation for householders' section on page 2.

## Wiring conversion charts

### Replacing existing Horstmann thermostats

	HRT4-B	DRT1
Common	1	Common
Call (N/O)	4	N/O
Satisfied (N/C)	3	N/C

### Replacing other thermostats

	HRT4-B	Drayton Digistat +	Danfoss RETB	Honeywell DT90E
Common	1	Com	3	A
Call (N/O)	4	On	2	B
Satisfied(N/C)	3	Off	1	C

# DIL switch settings – TPI temperature control software

Thermostats using TPI (Time Proportional Integral) control algorithms will reduce the temperature swing that normally occurs when using traditional bellows or thermally operated thermostats. As a consequence, a TPI regulating thermostat will maintain the comfort level far more efficiently than any traditional thermostat.

When used with a condensing boiler, the TPI thermostat will help to save energy as the control algorithm allows the boiler to operate in condensing mode more consistently compared to older types of thermostat.

- DIL switch numbers 7 and 8 should be set as diagram opposite.
- For Gas boilers set the TPI setting to 6 cycles per hour. (Default setting)
- For Oil boilers set the TPI setting to 3 cycles per hour.
- For Electric heating set the TPI setting to 12 cycles per hour.

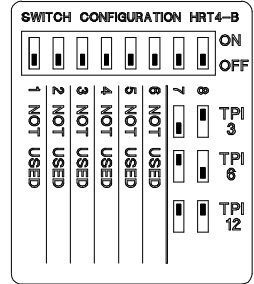

Switch positions for different TPI settings.

## Thermostat specifications HRT4-B

Power Supply	2 x AAA alkaline batteries
Contact rating	3 (1)amp at 230v AC
Temperature accuracy	+/- 0.5°C
Contact type	Micro disconnection Volt free changeover
Dimensions	86mm x 86mm x 36.25mm
Pollution control	Degree2
Design standard	EN60730 – 2-9
Temperature range	HRT4-B 5-30°C
Rated Impulse voltage	Cat 1 - 1500v
Enclosure protection	IP30



**HORSTMANN**

### Horstmann Controls

South Bristol Business Park, Roman Farm Road, Bristol BS4 1UP  
 E-mail: [sales@horstmann.co.uk](mailto:sales@horstmann.co.uk)  
 Web site: [www.horstmann.co.uk](http://www.horstmann.co.uk)

